

 **KYUSHU-TECHNO** Co., Ltd.



圧倒的な圧送力

コンクリートポンプ圧送車  **KW 3Z19.**

販売総代理店

有限会社 **キュウシュウテクノ**

TEL 092-976-2706 FAX 092-976-2707

〒811-2502 福岡県粕屋郡久山町山田2196-1

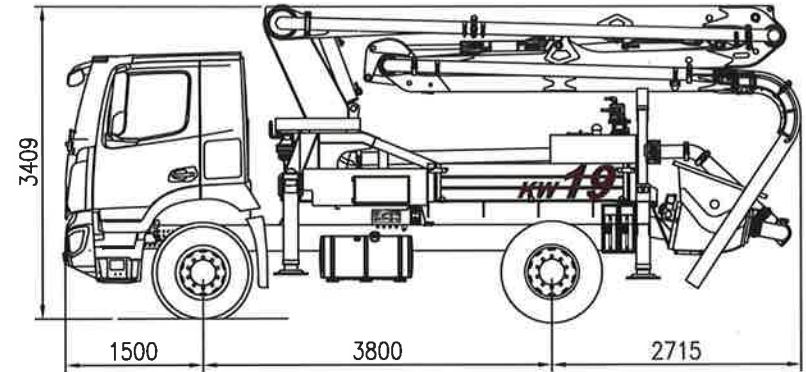
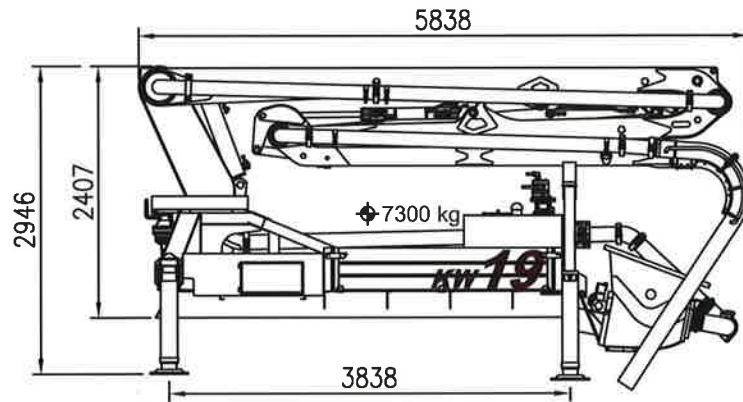

Empty Weight	3460 Kg	2220 Kg	1240 Kg
Mounted Weight	10750 Kg	3520 Kg(Max. 4000Kg)	7230 Kg(Max. 8000Kg)

Note : Mounted on a ISUZU truck as sample. Dimensions and weights will vary with different truck model and specifications.

Pumping Unit Specification

	8 B仕様	9 B仕様
Rod Side	80 m ³ /h	100 m ³ /h
Piston Side	54 m ³ /h	67 m ³ /h
Rod Side	71 kg/cm ²	53 kg/cm ²
Piston Side	105 kg/cm ²	80 kg/cm ²
Stroke Per min(Rod)	36	
Delivery Cylinder	φ200	
Stroke Length	1,200mm	
S-Valve	φ200×φ125	
Hydraulic System Pressure	350	
Hydraulic Pump Model	Rexroth A4VG125	
Switching Type	Electrical	
Max. Aggregate Size	40mm	
Hopper Capacity	0.6m ³ (600Liters)	
Water Pump Pressure	20Bar	
Water Tank Capacity	300L	

Boom Specification

Number of Booms	3+1
Folding Type	Z Folding
Vertical Reach	18.5M
Horizontal Reach	14.6M
Reach Depth	6.8M
Unfolding Height	4.8M
Section Articulation	90°/180°/240°
Rotation	365°
Delivery Line	125 mm
End Hose Length	3.5M
Proportional Boom Control	YES
Outrigger Spread-Front	3.4M
Outrigger Spread-Rear	2.9M

Working Diagram

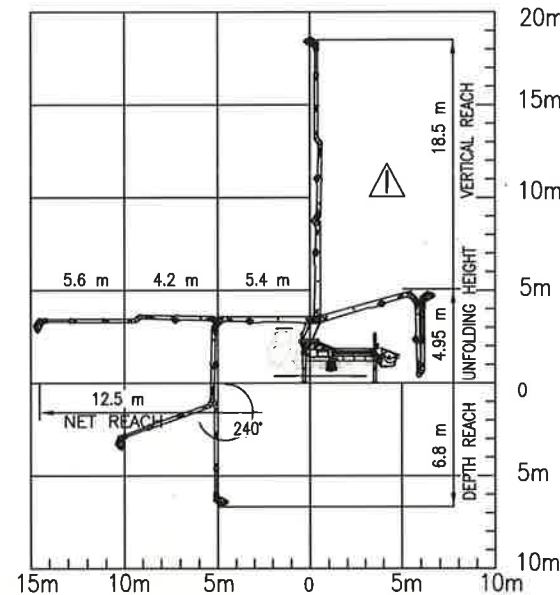

⚠ Don't work with the end nose in caution area.

Outrigger Diagram

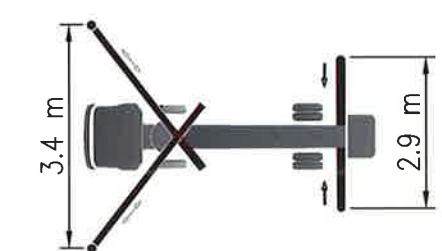

Unfolding Diagram



KW3Z19.